

Stationary Upper Platen, Movable Lower Platen Type Vertical Injection Molding Machine Model : SAV - 30 - 30 - P

General Purpose Vertical Injection Molding Machine
which was creatively developed in Japan 36 years ago.
A most popular vertical machine for insert-molding.
Applicable for general products to precision ones.

◆ Injection Unit

- * Vertical Inline-screw
- * Programmed Injection Control
- * Back Pressure Control
- * Screw Suck-back
- * 3 Zone Barrel Temperature Control
- * Nozzle Retracting by Cylinders

◆ Clamping Unit

- * Direct Hydraulic Clamp with booster
- * High precision oilless guide bush
- * Programmed Clamp Control
- * Reliable Mechanical Stop Ejector
- * Stepless Mechanical Safety Rod

◆ Electronic Control Unit

- * SANTROL 3500 Process Controller
- * Touch-Panel EL-LCD For
Programming Conditions
- * With Monitor/Alarm Function

◆ Hydraulic Unit

- * Variable Displacement Axial Plunger
Pump For Power Saving
- * Maintenance Easy Hydraulic System
- * Large Capacity Oil Reservoir
And Oil Cooler
- * Oil Cleaning System Eliminating
Through Life Oil-Exchange

◆ Ancillary Equipment (Option)

- * Hopper Drier or Hopper With Heater
- * Nozzle Pressure Monitor
- * Mold Temperature Controller
- * Automation System For Application
- * Special Injection Barrel Unit



SANJO SEIKICO., LTD.

— INJECTION MACHINES, MOLD & RELATED EQUIPMENTS —

Stationary Upper Platen, Movable Lower Platen Type Vertical Injection Molding Machine

Model : SAV - 30 - 30 - P

Specifications

Screw Diameter	mm	18	22	26	Clamping Force	kN	300
Injection Capacity	cm ³	15	20	30	Heater Capacity	kW	Approx. 3.1
Injection Pressure	MPa	250	247	177	Motor Capacity	kW	3.7
Injection rate	cm ³ /sec	13	19	27	Machine Weight	t	Approx. 1.0
Plasticizing capacity	Kg/h	5	8	10			

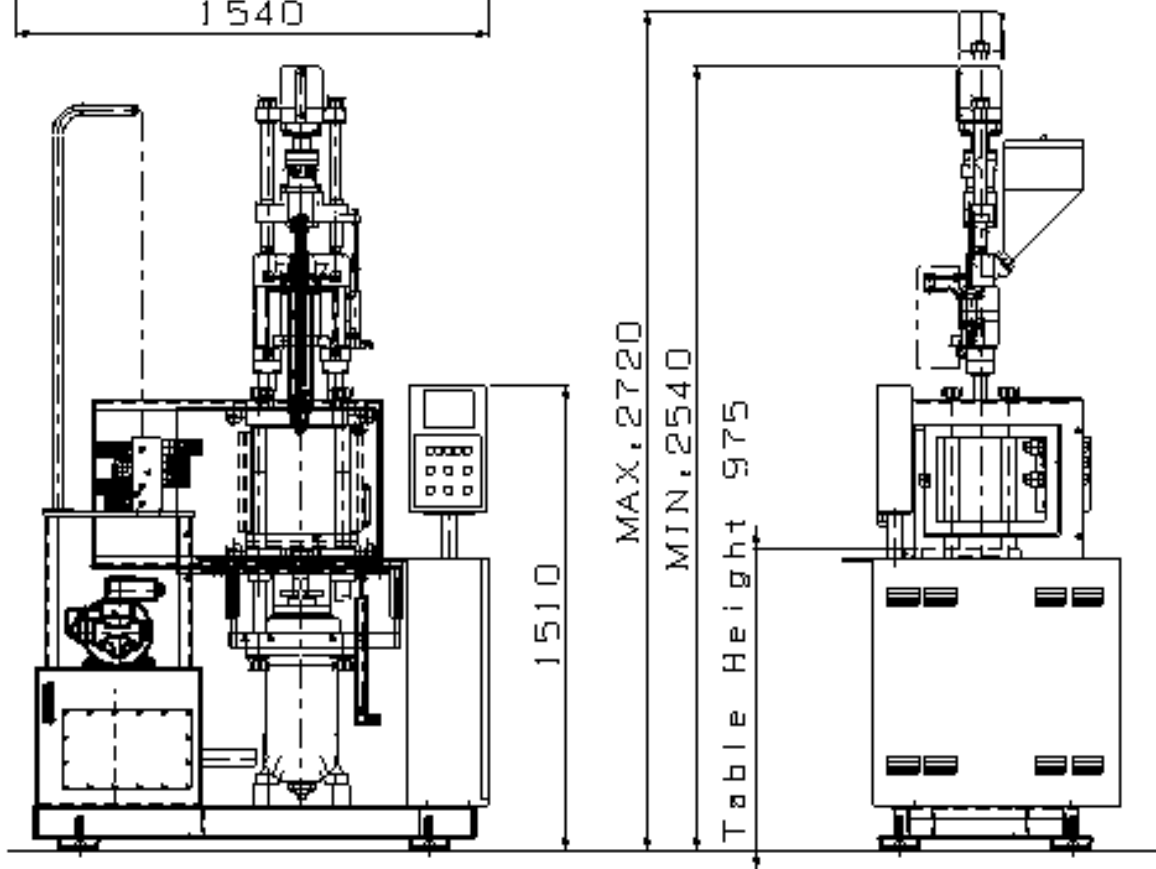
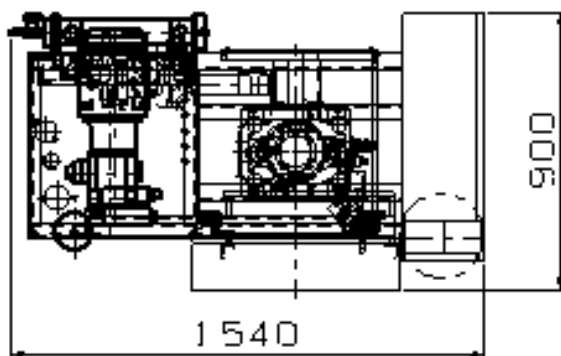

SANJO SEIKICO., LTD.
— INJECTION MACHINES, MOLD & RELATED EQUIPMENTS —

TEL 048-259-2790

http // www.sanjo.co.jp

E-mail s_eigyoun@sanjo.co.jp

Stationary Upper Platen, Movable Lower Platen Type Vertical Injection Molding Machine Model : SAV - 30 - 30 - P

◆ Platen (Option)

- * Tap Layout
- * Ejector Rod Layout
- * Upper Ejector

Movable Lower Platen

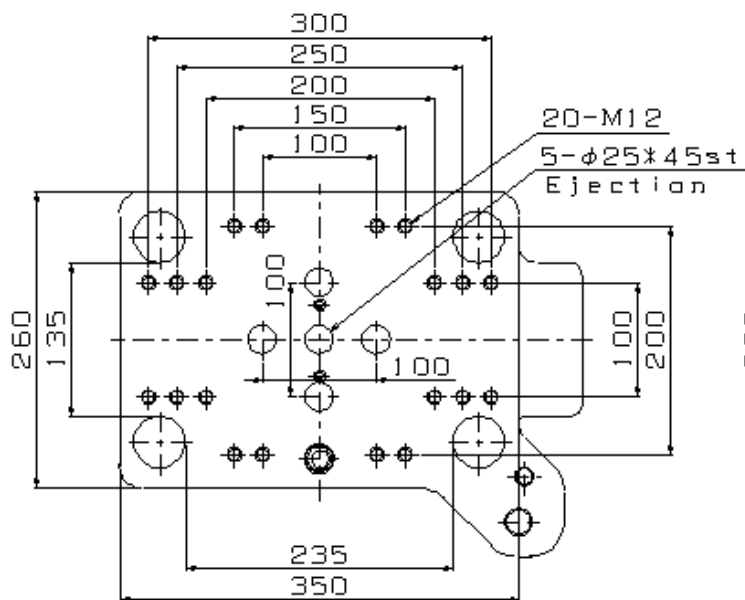

Stationary Upper Platen

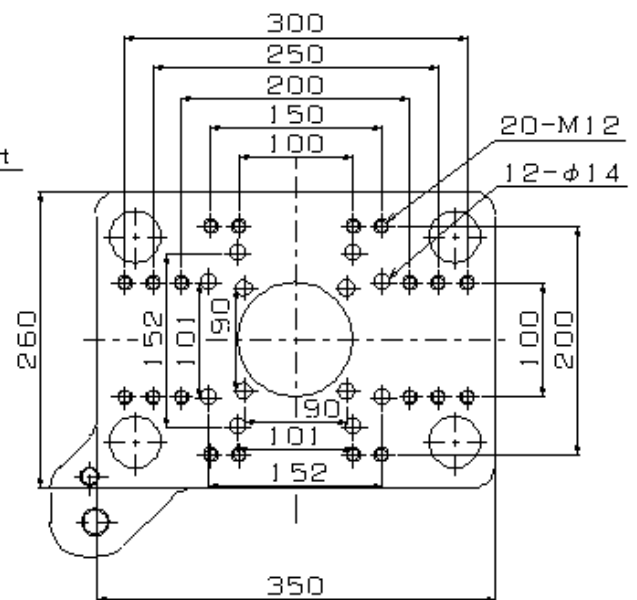

Nozzle Details

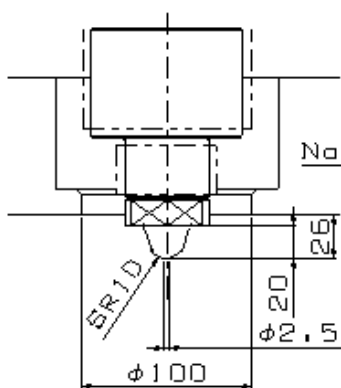

Mold Height/Stroke

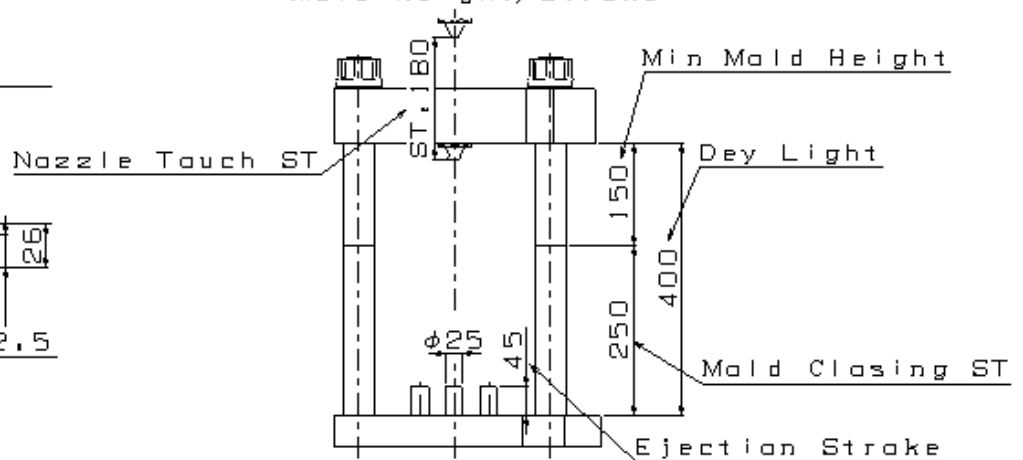

SANJO SEIKICO, LTD.

INJECTION MACHINES, MOLD & RELATED EQUIPMENTS